

Enstrom Helicopter Corporation 480 and 480B STC Certified Lead Acid Battery Installations



FAA STC SR01067DE

Main Battery Upgrade –

Original equipment lead acid battery, Gill 7641-20 or G-641, is replaced with RG-641 (24 volt, 17 Ah) TSO-C-173a Authorized battery.

- Premium Sealed Lead Acid Battery Technology
- Proprietary PolyGuard® Separator System
- Robust Turbine Starting Design for Improved Reliability, Safety and Sustainable Starting Power
- Fully Tested and Installation Ready
- Maintenance Free Operation
- Longer Battery Life
- Hazmat Exempt Transportation
- Fully Recyclable - the Green Solution
- Hassle Free Warranty
- TSO C173a Approved
- Available through a Worldwide Distribution Network

Made in the U.S.A.

CONCORDE BATTERY CORPORATION

2009 San Bernardino Road | West Covina, CA 91790 USA
626-813-1234 | Fax 626-813-1235 | www.ConcordeBattery.com
ISO 9001 + AS9100 | Crafted for Quality in the U.S.A.



RG-641 (17 Ah)

Specifics:

STC provides for the installation of Concorde RG-641 valve regulated sealed lead acid (VRSLA) battery in place of the original equipment lead acid main battery in Enstrom Helicopter Corporation 480 and 480B models.

Concorde's RG-641 battery has the same design footprint and is interchangeable without airframe modification.

1. Remove the existing main battery from the aircraft in accordance with (IAW) Rotorcraft Maintenance Manual Section 6-28.
2. Install the RG-641 replacement battery IAW Section 6-31.
3. Update the rotorcraft's weight and balance.
4. Insert the Concorde FAA Approved ICA in the appropriate location in the AMM.
5. Complete the appropriate forms and return the rotorcraft to service.

Notes: The model 480 & 480B rotorcraft are also certified to use a 17 Ah nicd battery. This STC only provides for replacement of the original equipment lead acid battery options.

...the heart of your aircraft®
CONCORDE

FAA STC SR01067DE

**Main Battery Upgrade –
RG-641, 17 Ah**

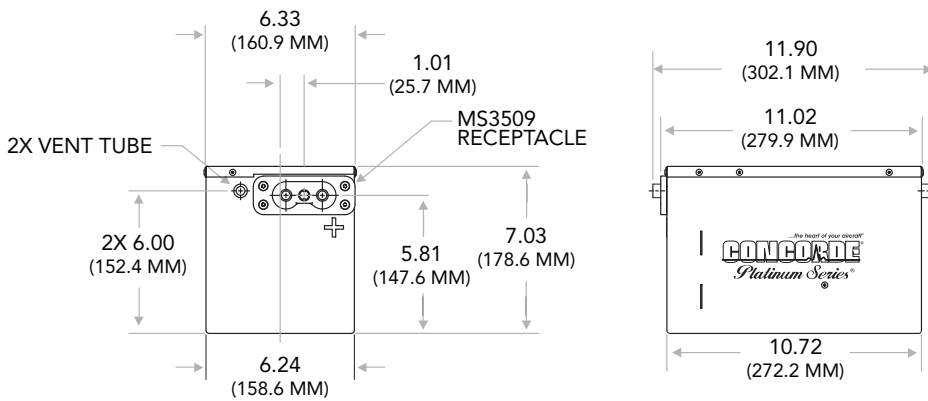

Part Number	Rated Capacity C1 in Ah	IPP 23°C / 74°F	IPR 23°C / 74°F	IPP -18°C / 0°F	IPR -18°C / 0°F	IPP -30°C / -22°F	IPR -30°C / -22°F	Maximum Weight
RG-641	17 Ah	900	625	600	425	450	300	41.5 LB / 18.8 KG

CONCORDE BATTERY CORPORATION

2009 San Bernardino Road | West Covina, CA 91790 USA
626-813-1234 | Fax 626-813-1235 | www.ConcordeBattery.com
ISO 9001 + AS9100 | Crafted for Quality in the U.S.A.

