

NOTES: UNLESS OTHERWISE SPECIFIED

1. MANUFACTURED AND INSPECTED IAW AS9100 QUALITY SYSTEM REQUIREMENTS.
2. ABBREVIATION USED IN TITLE IS: VALVE REGULATED SEALED LEAD ACID (VRSLA).
3. SEE DRAWING NO. CB-00425 AND PROCEDURE P-1000 FOR ASSEMBLY AND TEST INSTRUCTION. PROCEDURES AND ASSEMBLY DRAWINGS ARE FOR INTERNAL USE ONLY.
4. BATTERIES ARE RATED IAW INTERNATIONAL ELECTROTECHNICAL COMMISSION STANDARD 60952-1 AND RTCA STANDARD DO-293, UNLESS OTHERWISE NOTED.
5. DIMENSIONS ARE INCH [MILLIMETER].

REVISIONS			
REV	DESCRIPTION	DATE	APPROVED
A	REVISED CONNECTOR TYPE	9/14/11	JBT
B	CAPACITY, 3.3A WAS 3.25A RAPID DISCHARGE, 33A WAS 32.5A	3/22/12	JBT

BATTERY POSITIVE (RED) BATTERY NEGATIVE (BLACK)

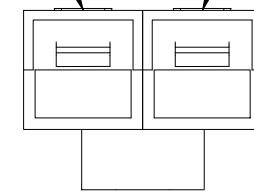

VIEW A-A
SCALE 2 : 1

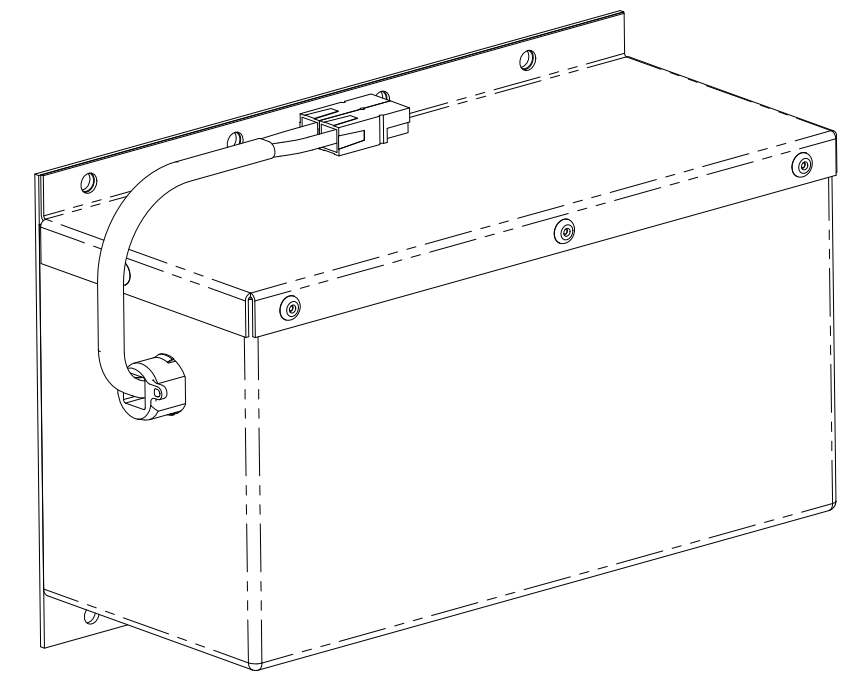

REFERENCE VIEW

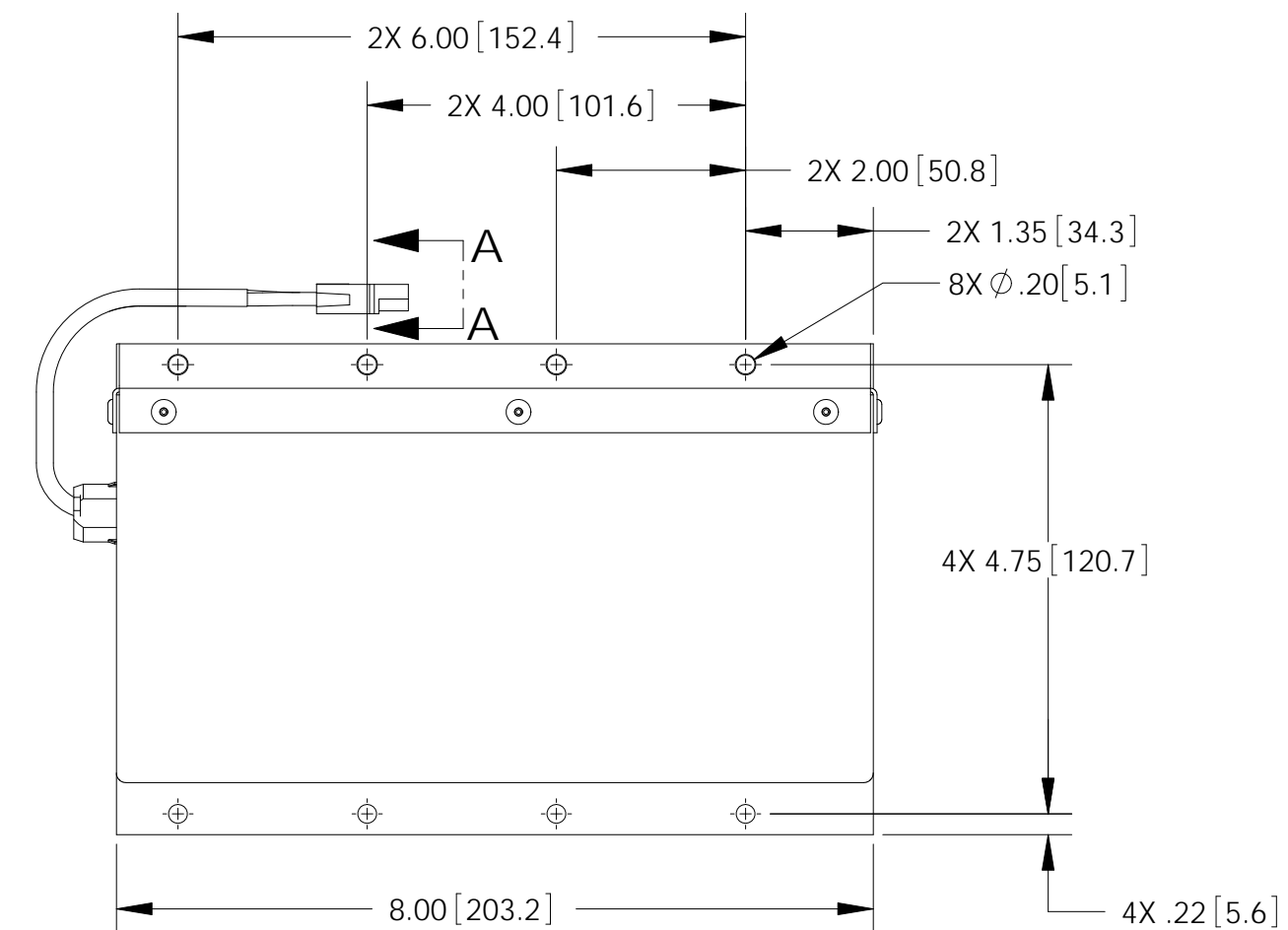
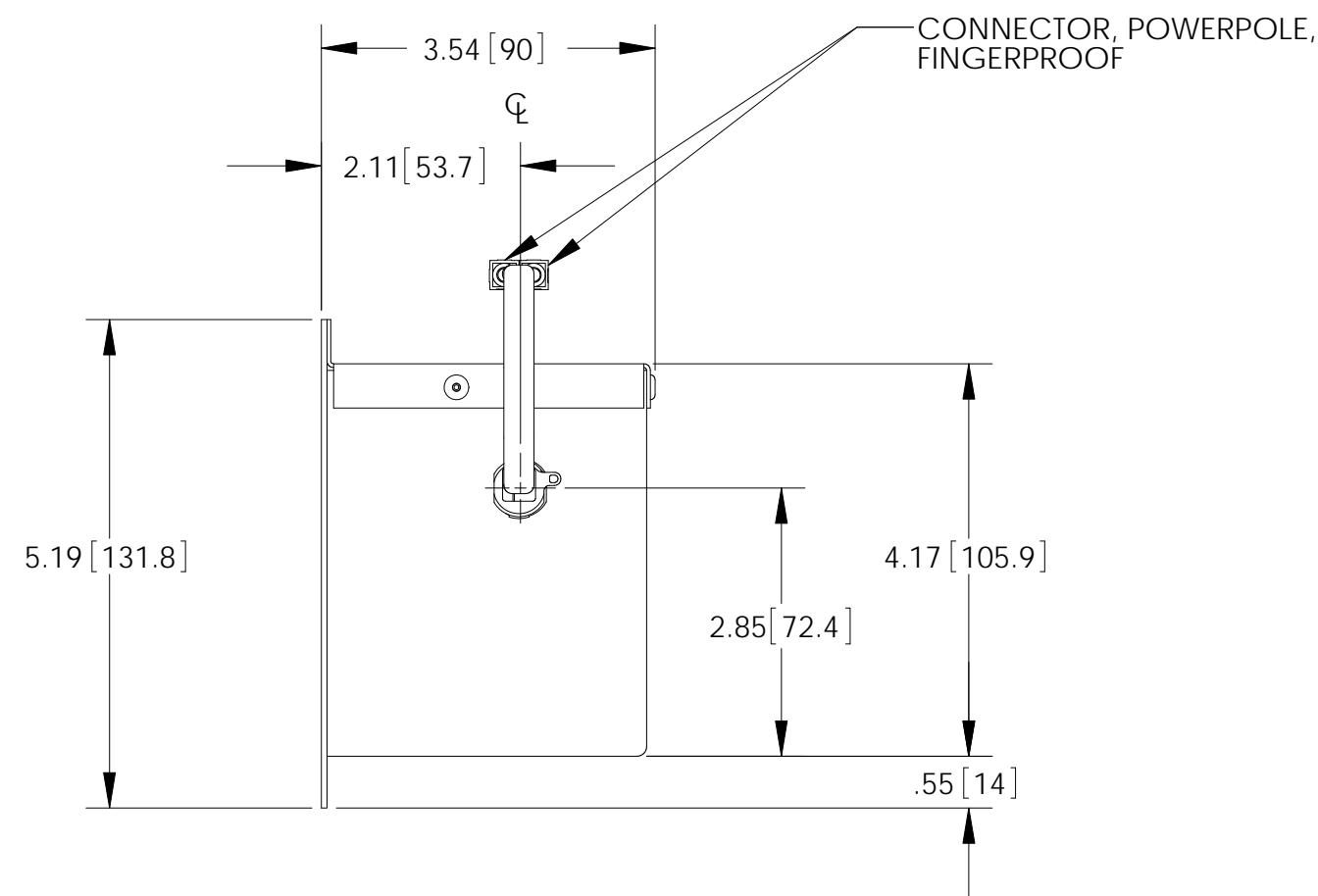

PART NUMBER	RG-300		
MAXIMUM WEIGHT	9.6 LBS [4.4 KG]		
RATED CAPACITY, C1	3.3 AH		
TEST TEMPERATURE	@23 °C (74 °F)	@-18 °C (0 °F)	@-30 °C (-22 °F)
CAPACITY, 3.3 A	3.3 AH	2.1 AH	1.5 AH
RAPID DISCHARGE, 33 A	1.9 AH	NOT RATED	0.7 AH

ENVELOPE DRAWING

UNLESS OTHERWISE SPECIFIED DIMENSIONS ARE IN INCHES TOLERANCES ARE:			CONTRACT NO.		CONCORDE BATTERY CORPORATION 2009 SAN BERNARDINO RD, W. COVINA, CA 91790		
FRACTIONS ±1/32	DECIMALS .XX ± .06 XXX ± .030	ANGLES ±1°	APPROVALS	DATE	TITLE		
			DRAWN D. AYALA	1/18/11	BATTERY, VRSLA, 24 VOLT		
TREATMENT NONE			CHECKED AMIII	1/28/11	SIZE	CAGE CODE	DWG NO.
FINISH NONE			APPROVED JBT	1/31/11	C	63017	RG-300
SIMILAR TO			ISSUED BT	3/22/12	SCALE	1:2	SHEET 1 OF 1
							REV B