

NOTES: UNLESS OTHERWISE SPECIFIED

1. MANUFACTURED AND INSPECTED IAW AS9100 QUALITY SYSTEM REQUIREMENTS.
2. SEE DRAWING NO. 9707 AND PROCEDURE P-1000 FOR ASSEMBLY AND TEST INSTRUCTION. PROCEDURES AND ASSEMBLY DRAWINGS ARE FOR INTERNAL USE ONLY.
3. REFER TO KIT DRAWING 5-0385 FOR CMM, MOUNTING HARDWARE, AND INSTALLATION INSTRUCTIONS.
4. DIMENSIONS ARE INCH [MILLIMETERS].
5. MAXIMUM WEIGHT: 1.0 LB [.45 KG]

REVISIONS			
REV	DESCRIPTION	DATE	APPROVED
A	REVISED NOTE 3: CMM WAS ICA, ADDED NOTE 5	7/19/12	JBT

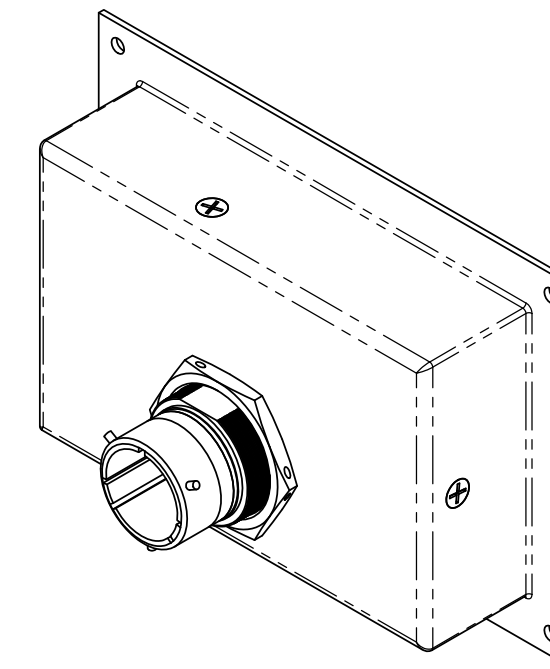
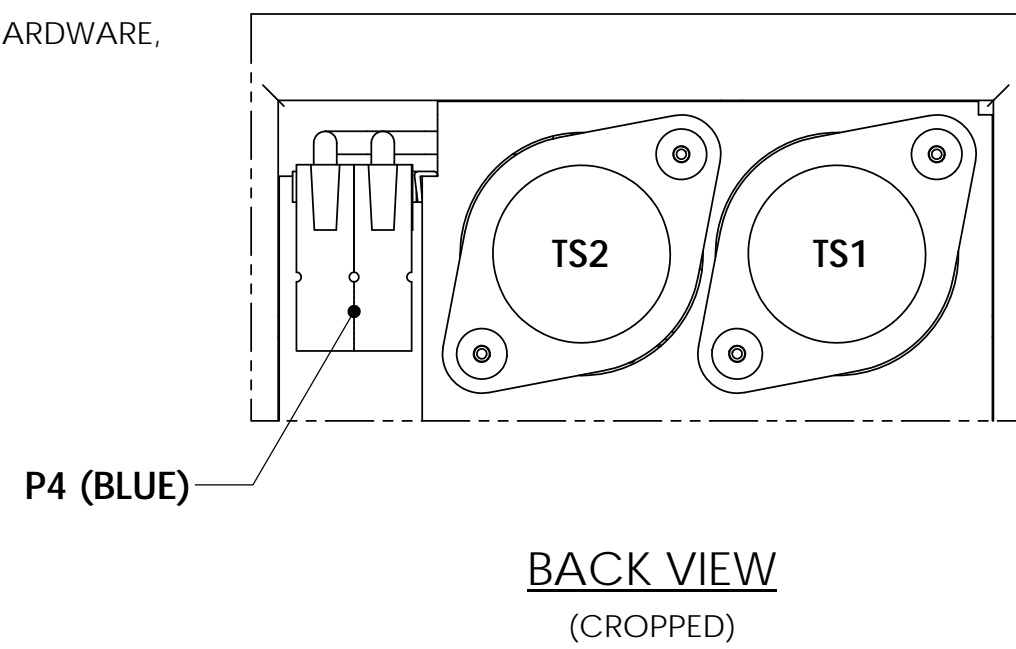

PART NUMBER: HCU-1

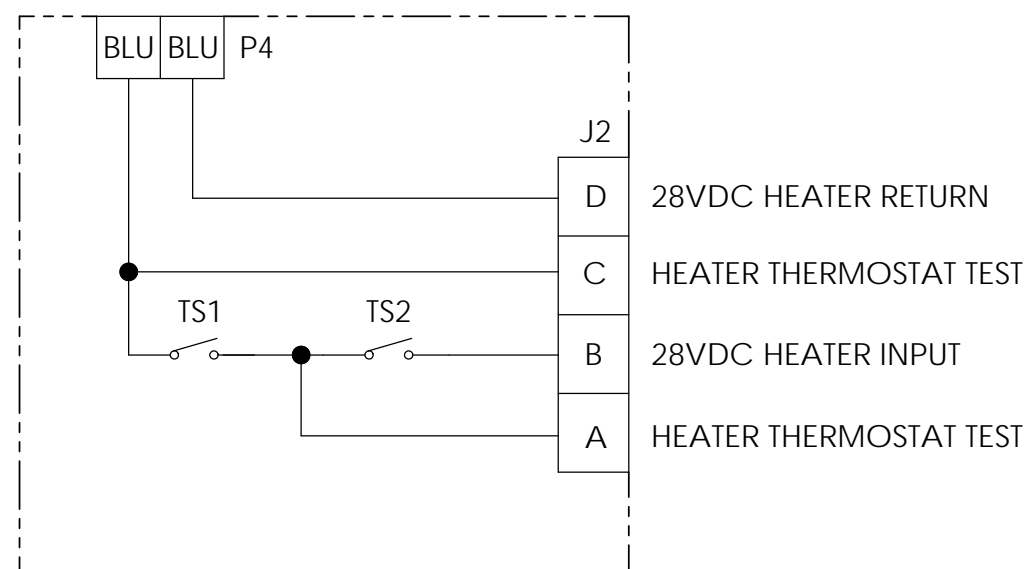
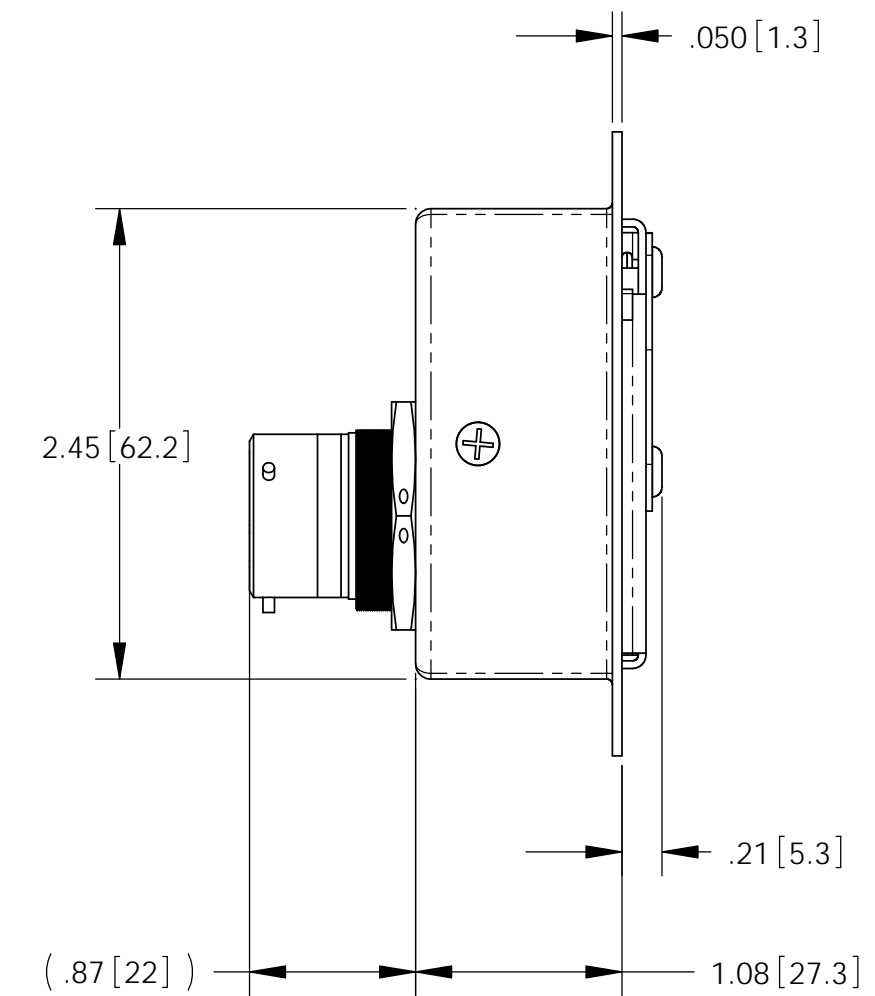
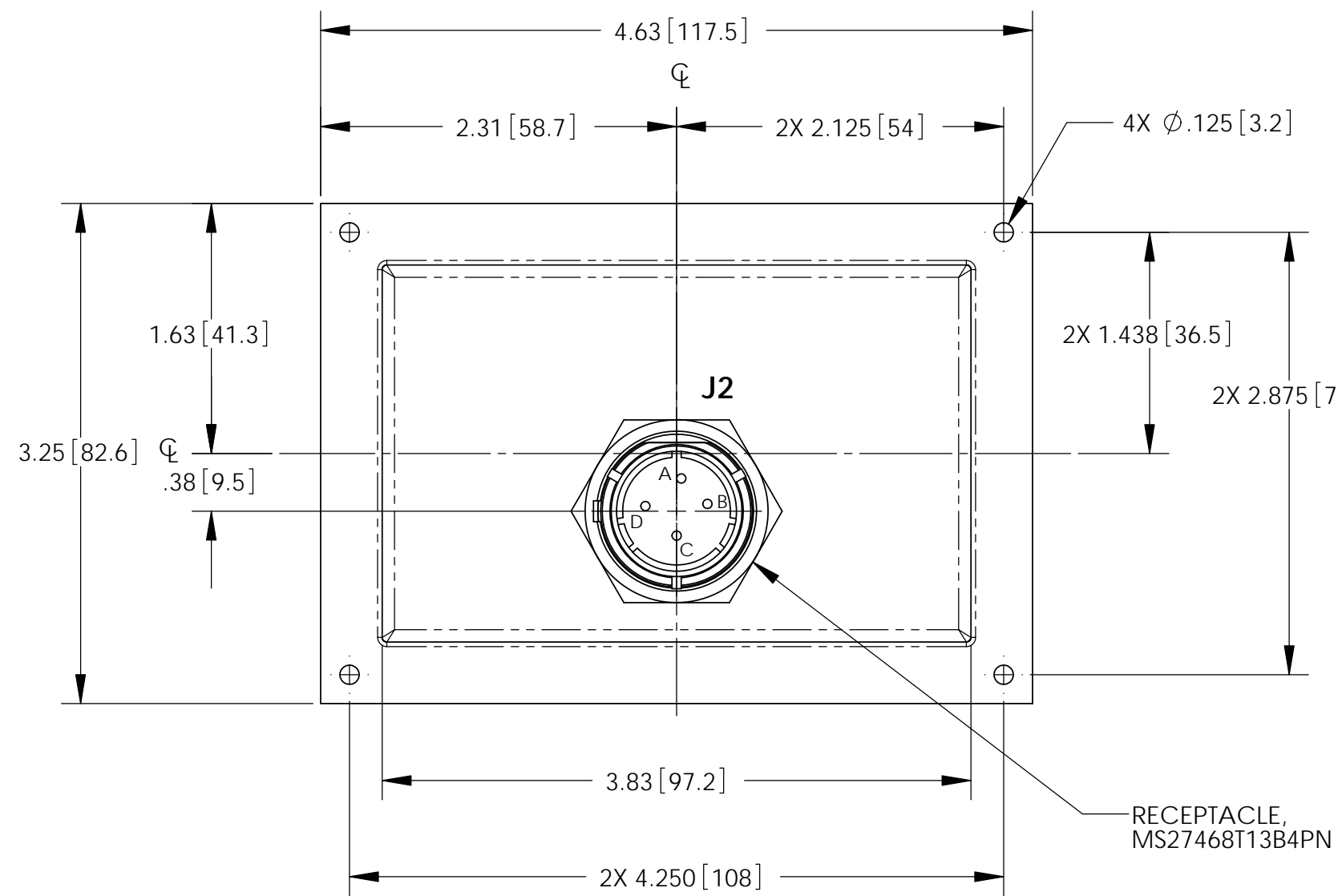

ELECTRICAL SCHEMATIC

ENVELOPE DRAWING

UNLESS OTHERWISE SPECIFIED DIMENSIONS ARE IN INCHES TOLERANCES ARE:			CONTRACT NO.		CONCORDE BATTERY CORPORATION 2009 SAN BERNARDINO RD, W. COVINA, CA 91790		
FRACTIONS	DECIMALS	ANGLES	APPROVALS	DATE	TITLE		
±1/32	.XX ± .06 XXX ± .015	±1°	DRAWN A. MISTRETTA	3/23/11	HEATER CONTROL UNIT, HCU-1		
TREATMENT	NONE	CHECKED AMIII	3/25/11	SIZE C	CAGE CODE 63017	DWG NO. HCU-1	REV A
FINISH	NONE	APPROVED JBT	3/26/11	SCALE 1:1	SHEET 1 OF 1		
SIMILAR TO	CALC WT	ISSUED BT	7/19/12				