

TURBINE AIRCRAFT BATTERY

HEATED | TSO AUTHORIZED

	Maximum Weight
RG-380E/53KH Fire Resistant Aluminum Container with Vent Louvers & Heater Control Unit Mount	96.0 LB / 43.6 KG
RG-380E/53KSH Fire Proof Stainless Steel Container with Vent Louvers & Heater Control Unit Mount	98.0 LB / 44.5 KG
RG-380E/53LH Fire Resistant Aluminum Container, Vent Tubes & Heater Control Unit Mount	96.0 LB / 43.6 KG
RG-380E/53LSH Fire Proof Stainless Steel Container, Vent Tubes & Heater Control Unit Mount	98.0 LB / 44.5 KG
Voltage	24 Volts
Rated Capacity C ₁	53 AH

IEC Rated for Peak Power (IPP) & 15 Second Power Rating (IPR)

IPP	IPR	IPP	IPR	IPP	IPR
At 23° C (74° F)		At -18° C (0° F)		At -30° C (-22° F)	
1650 A	1200 A	1325 A	1000 A	1125 A	800 A

Rated in accordance with International Standard 60952-1

Features: Internal AC Heater – 115 VAC
 Internal DC Heater – 28.25 VDC

ISO 9001 + AS9100

The data/information contained herein has been reviewed & approved for general release on the basis that this document contains no export controlled information.

Concorde’s superior Platinum Series® batteries have been proven reliable, durable and safe in turbine aircraft applications for more than two decades. Concorde’s valve regulated sealed recombinant gas (RG®) Turbine Starting aircraft batteries are constructed with advanced lead acid, absorbed glass mat (AGM) technology.

- Aerobatic – Non-spillable at any altitude or attitude
- Dual Purpose – Emergency or main starting
- Emergency Power - Reliable essential power in the event of a generator failure
- Factory Tested – Assures airworthiness & installation readiness
- Low impedance design – Unique design features reduce internal resistance
- Maintenance Free – No water replenishment is required – ever
- Proprietary PolyGuard® Separators – Added protection against shock & vibration
- Proven Technology – Dependable, durable and safe
- Quick Disconnect – MS3509 conforming receptacle
- Safe – No threat of thermal runaway & no deep cycling
- Starting Power – Superior starting power in hot & cold climates
- Transport – Ship Hazmat Exempt whether by land, sea or air
- TSO Approved – FAA TSO-C173 approved
- Worldwide – Available through a professional network of worldwide distributors

Concorde designs and manufactures over 90 models of Original Equipment and direct replacement batteries for fixed wing and rotary aircraft and has a reputation for designing application specific solutions. Concorde batteries are installed as Original Equipment by the majority of aircraft manufacturers and adopted by military aircraft operators worldwide.

Manufacturing certified aircraft batteries for over 30 years: Military, TSO, FAA-PMA , OEM



RG-380E/53KH

RG-380E/53LH
 RG-380E/53LSH
 (not shown)

RG-380E/53KSH

RG-380E/53KH, RG-380E/53KSH, RG-380E/53LH & RG-380E/53LSH

RG-380E/53KH & RG-380E/53KSH

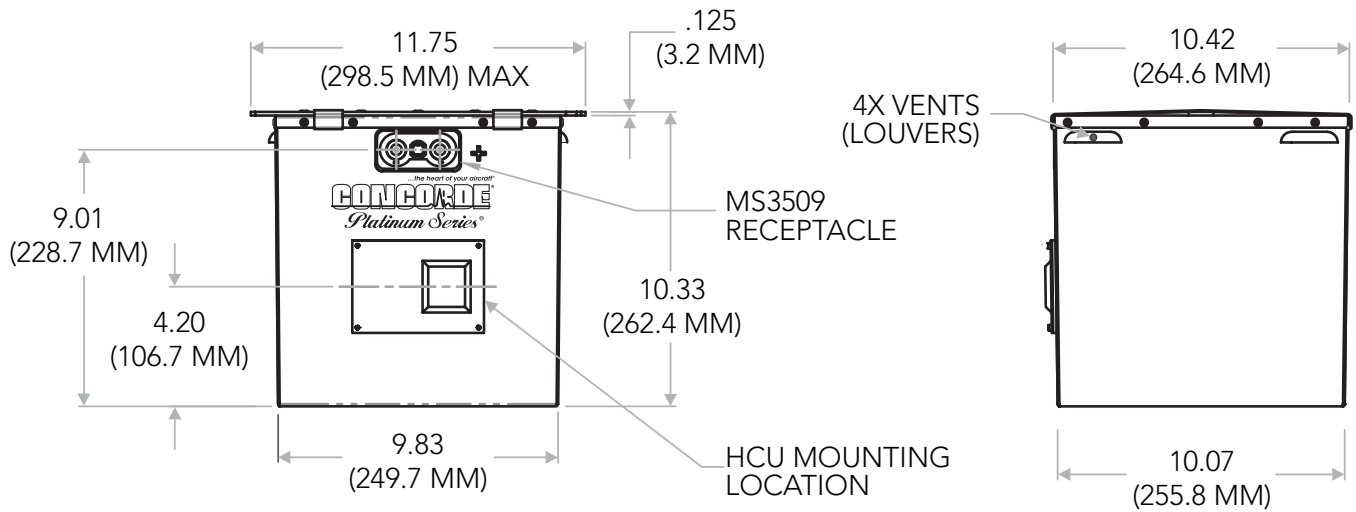

RG-380E/53LH & RG-380E/53LSH

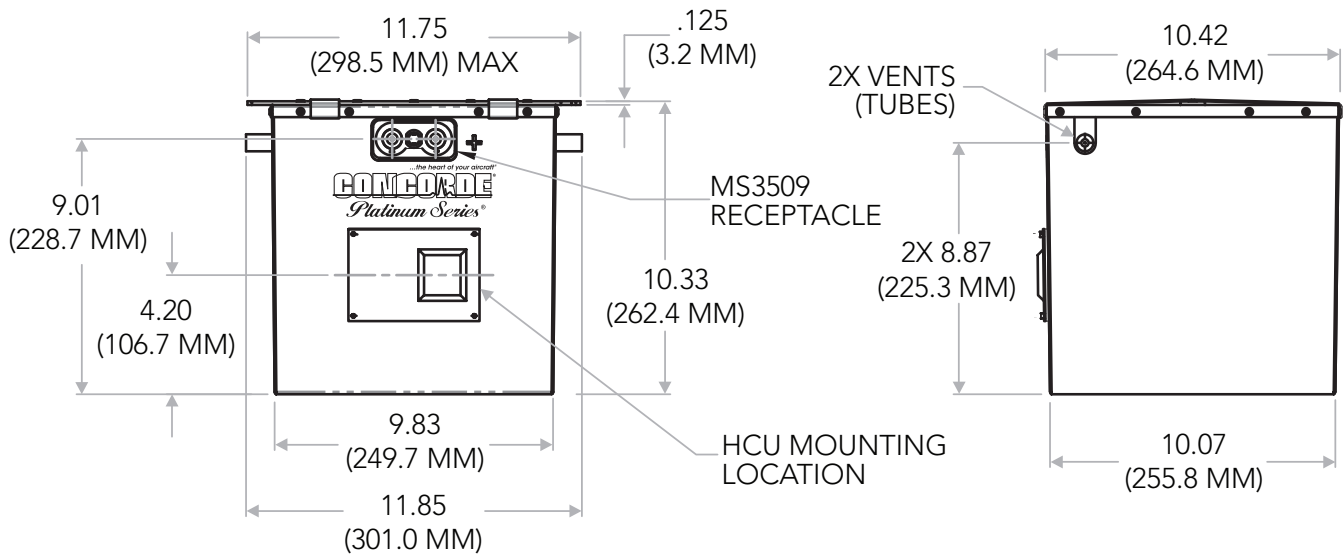

RG-380E/53KH, RG-380E/53KSH, RG-380E/53LH & RG-380E/53LSH